

Features

- 3000W Peak Pulse Power Dissipation
- Glass Passivated Die Construction
- Excellent Clamping Capability
- Fast Response Time
- **Lead Free Finish/RoHS Compliant Version (Note 4)**
- **Qualified to AEC-Q101 Standards for High Reliability**

Mechanical Data

- Case: SMC
- Case Material: Molded Plastic. UL Flammability Classification Rating 94V-0
- Moisture Sensitivity: Level 1 per J-STD-020D
- Terminals: Solderable per MIL-STD-202, Method 208
- Lead Free Plating (Matte Tin Finish).
- Polarity Indicator: Cathode Band
- Marking Information: See Page 2
- Ordering Information: See Page 2
- Weight: 0.21 grams (approximate)

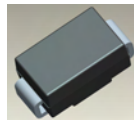

Top View

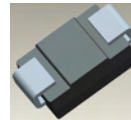

Bottom View

Maximum Ratings @T_A = 25°C unless otherwise specified

Single phase, half wave, 60Hz, resistive or inductive load.
For capacitive load, derate current by 20%.

Characteristic	Symbol	Value	Unit
Peak Pulse Power Dissipation (Note 1)	PPK	3000	W
Peak Forward Surge Current, 8.3ms Single Half Sine Wave Superimposed on Rated Load (Notes 2 & 3)	I _{FSM}	300	A

Thermal Characteristics

Characteristic	Symbol	Value	Unit
Operating and Storage Temperature Range	T _J , T _{STG}	-55 to +175	°C

Electrical Characteristics @T_A = 25°C unless otherwise specified

Part Number	Reverse Standoff Voltage	Breakdown Voltage V _{BR} @ I _T (Note 5)		Test Current	Max. Reverse Leakage @ V _{RWM}	Max. Clamping Voltage @ I _{PP}	Max. Peak Pulse Current I _{PP}	Typical Total Capacitance (Note 7)	Marking Code
		Min (V)	Max (V)						
See Notes 4, 6	V _{RWM} (V)	Min (V)	Max (V)	I _T (mA)	I _R (μA)	V _C (V)	(A)	C _T (pF)	
3.0SMCJ5.0A	5.0	6.40	7.07	10	1000	9.2	326.1	8,000	HDE
3.0SMCJ20A	20.0	22.20	24.5	1.0	5.0	32.4	92.6	3,300	HEV
3.0SMCJ22A	22.0	24.40	27.0	1.0	5.0	35.5	84.5	3,000	HEX
3.0SMCJ24A	24.0	26.70	29.5	1.0	5.0	38.9	77.1	3,000	HEZ
3.0SMCJ28A	28.0	31.10	34.4	1.0	5.0	45.4	66.1	1,800	HFG
3.0SMCJ30A	30.0	33.30	36.8	1.0	5.0	48.4	62.0	1,700	HFK
3.0SMCJ58A	58.0	64.40	71.2	1.0	5.0	93.6	32.1	1,500	HGG

- Notes:
1. Non-repetitive current pulse, per Fig. 4 and derated above T_A = 25°C per Fig. 1.
 2. Mounted on 8.00mm² (0.013mm thick) land areas.
 3. Measured with 8.3ms single half sine-wave. Duty cycle = 4 pulses per minute maximum.
 4. EU Directive 2002/95/EC (RoHS). All applicable RoHS exemptions applied, see *EU Directive 2002/95/EC Annex Notes*.
 5. V_{BR} measured with I_T current pulse = 300μs.
 6. Additional voltages may be available upon request. Please contact the Diodes Incorporated sales department for assistance.
 7. V_R = 0V, f = 1MHz

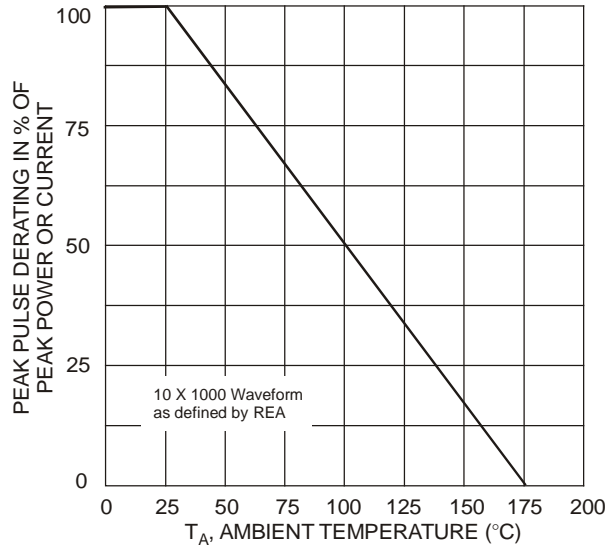

Fig. 1 Pulse Derating Curve

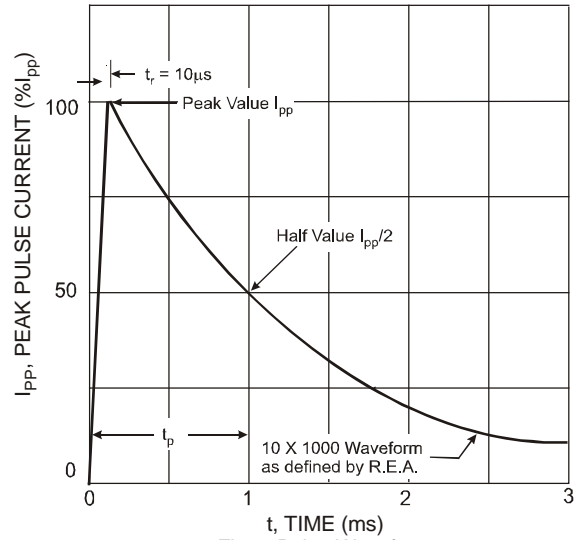

Fig. 2 Pulse Waveform

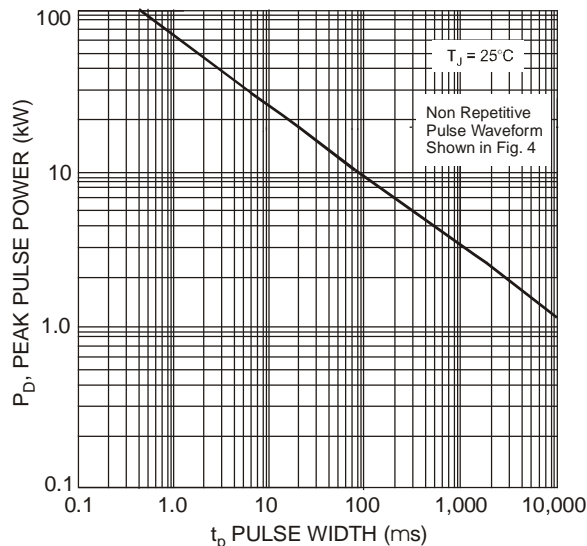

Fig. 3 Pulse Rating Curve

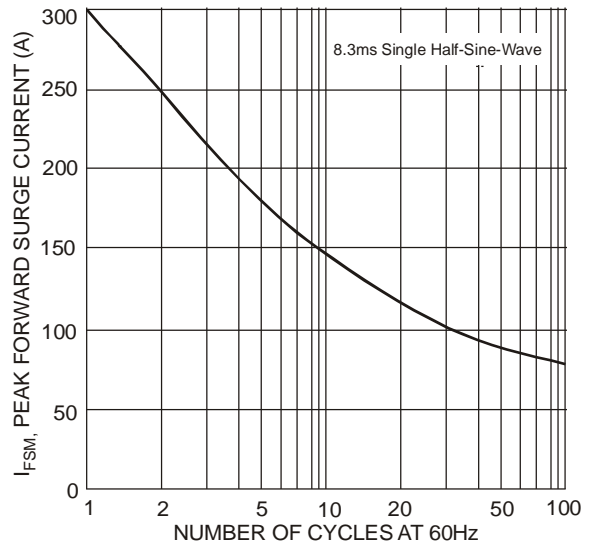

Fig. 4 Maximum Non-Repetitive Surge Current

Ordering Information (Note 8)

Part Number	Case	Packaging
3.0SMCJ5.0A-13	SMC	3000/Tape & Reel
3.0SMCJ20A-13	SMC	3000/Tape & Reel
3.0SMCJ22A-13	SMC	3000/Tape & Reel
3.0SMCJ24A-13	SMC	3000/Tape & Reel
3.0SMCJ28A-13	SMC	3000/Tape & Reel
3.0SMCJ30A-13	SMC	3000/Tape & Reel
3.0SMCJ58A-13	SMC	3000/Tape & Reel

Notes: 8. For packaging details, go to our website at <http://www.diodes.com/datasheets/ap02007.pdf>.

Marking Information

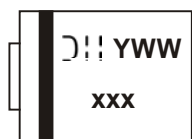

xxx = Product type marking code,
See Electrical Characteristics Table
D!! = Manufacturers' code marking
YWW = Date code marking
Y = Last digit of year ex: 7 for 2007
WW = Week code 01 to 52

Package Outline Dimensions

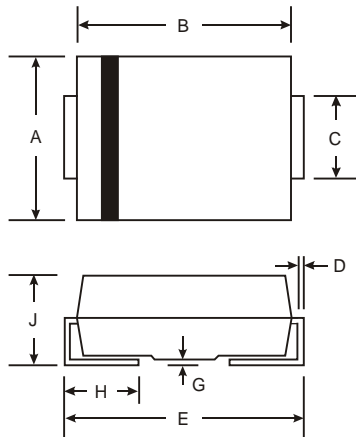

SMC		
Dim	Min	Max
A	5.59	6.22
B	6.60	7.11
C	2.75	3.18
D	0.15	0.31
E	7.75	8.13
G	0.10	0.20
H	0.76	1.52
J	2.00	2.62
All Dimensions in mm		

Suggested Pad Layout

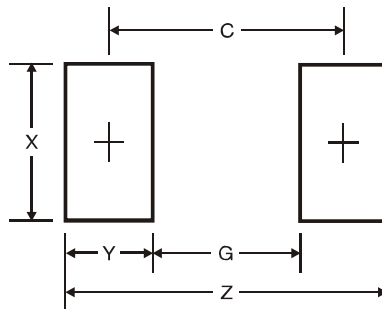

Dimensions	Value (in mm)
Z	9.3
G	4.4
X	3.3
Y	2.5
C	6.8

IMPORTANT NOTICE

Diodes Incorporated and its subsidiaries reserve the right to make modifications, enhancements, improvements, corrections or other changes without further notice to any product herein. Diodes Incorporated does not assume any liability arising out of the application or use of any product described herein; neither does it convey any license under its patent rights, nor the rights of others. The user of products in such applications shall assume all risks of such use and will agree to hold Diodes Incorporated and all the companies whose products are represented on our website, harmless against all damages.

LIFE SUPPORT

Diodes Incorporated products are not authorized for use as critical components in life support devices or systems without the expressed written approval of the President of Diodes Incorporated.